

## KPR-BSB

### 990kW Multi-fuel Boiler - Straw, woodchips, pellets and sawdust

The latest boiler in the range, the KPR-BSB is constructed as a traditional 3-pass boiler with a large fire box and horizontal flue gas pipes. This not only increases efficiency and reduces emissions but also reduces the number of boiler starts.

The straw is automatically transported to the shredder. A screw transports the shredded straw to a stone trap, where stones etc. are removed, before the straw is sucked into the boiler room. In the boiler room the straw is transported from the cyclone in a closed screw—directly into the boiler unit. In the water cooled hearth, straw is converted to heat at temperatures between 1000 and 1200C.

- RHI Compliant Straw / Multifuel boiler
- Well priced / Short payback period
- Fully automatic, robust & reliable
- 90% efficiency
- Burns up to 50% moisture
- Wood chip, straw and sawdust feeder system
- Five year mechanical guarantee and two year electrical guarantee

# Topling

Biomass energy systems



**Custom built for each installation—prices on application**

**Call 0844 740 792 for a no obligation quotation.**

## Topling KPR-BSB Dual Fuel Boiler 990kW 110/90

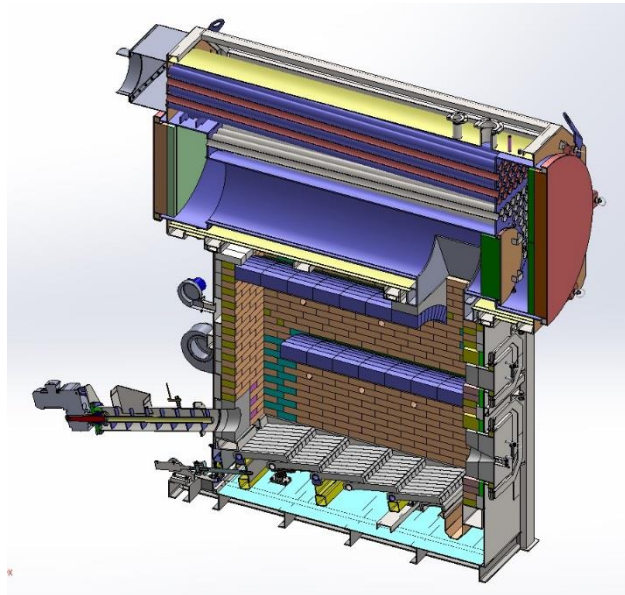

Consisting of:

- 3 pass boiler/heat exchanger with moving grate
- Auto ignition and auto de-ashing
- Touch screen control panel
- 16000l Accumulator
- Multicyclone & Bag Filter
- Bale conveyor and shredder
- Optional woodchip sweeping arm system
- 5 year warranty on boiler body, 2 year warranty on electrical components
- Permissible fuels – Miscanthus, Wheat Straw, Rape and woodchip G50

RRP – Straw only – installed price £225,000 exc. Vat

RRP – Dual Fuel option – installed price £240,000 exc. Vat

